

# TS ARAX 2.8/80

## PHOTOGRAPHIC LENS

### Operations manual

#### 1. GENERAL GUIDELINES

The TS ARAX 2,8/80 (TS = Tilt Shift) camera compact lens with tilt and shift movements is a wide-angle, eleven element large aperture optical system, suited for producing extremely high quality photographs. The effects of large-format camera movements can be obtained with TS ARAX lenses for 35mm cameras.

The TS ARAX 2,8/80 lens is available for 35mm type cameras:

- Nikon AI
- Canon EOS
- Canon FD
- Minolta Dynax
- Minolta MD
- Pentax K
- M42 (Zenit, Praktica, etc.)
- Olympus OM1 ... OM3
- Contax
- Yashica
- Leica R
- Rolleyflex

In terms of structure the optical block tilting mechanism is designed to provide the photographer with the power correct the image distortions encountered during shooting architecture, panoramas, and products.

The optical elements of the lens have a special multi-layer coating (MC), they improve image quality and increase contrast range by enhancing integral transmission and decreasing the dispersion.

The camera lens operates in the temperature range from minus 15 to 45° C.

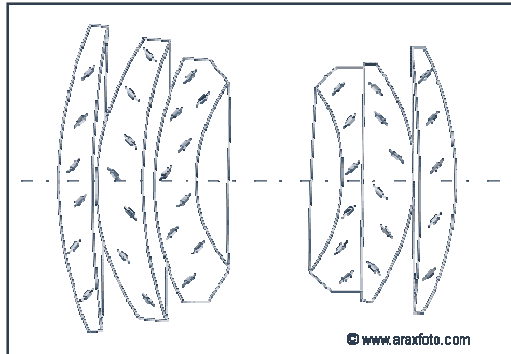

#### 2. TECHNICAL SPECIFICATIONS

- Image ratio, mm: 24x36
- Focal distance, mm: 80
- Aperture ratio: 1:2,8
- Design: 6 elements, 5 groups
- Angle of view without shifting optical block: 45°
- Short focusing range, m: 0,6
- Aperture range: 2,8 - 22
- Aperture operation: Manual
- Threads for light filters, mm: 62
- Maximum shift of the optical block, mm: 11
- Maximum tilt of the optical block, mm: 8
- Turning angle of the optical block relative to bayonet axis: 360°
- Maximal diameter, mm, not more than: 72
- Overall dimensions, mm, not more than: 82x85
- Weight, kg, not more than: 0,85

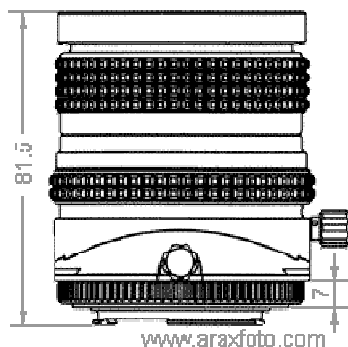

Figure 1

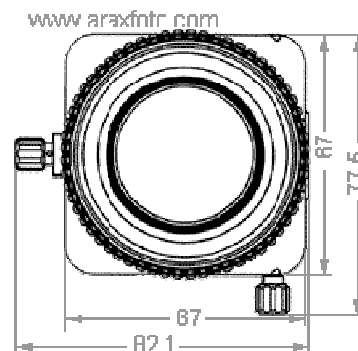

Figure 2



Figure 3

- |                        |                       |
|------------------------|-----------------------|
| 1. Focusing ring       | 6. TS plate           |
| 2. Distance scale      | 7. Tilt handle        |
| 3. Deep of field scale | 8. Tilt scale         |
| 4. Aperture scale      | 9. 360° rotating ring |
| 5. Aperture ring       | 10. Shift handle      |
|                        | 11. Shift scale       |

### 3. OPERATIONS INSTRUCTIONS

#### 3.1. Lens installation on the camera and its removal

Install and remove the lens as it written in the camera's operation manual.

#### 3.2 Focusing

It is preferable to perform focusing at maximum aperture by rotating the focusing ring 1, on which focusing scale (distance) 2 is marked. If focusing is required after tilting and shifting the optical block, then the microprisms or camera viewfinder wedges' surface dim out. In this case it is necessary to control image sharpness according to the screen's matte area. The distance scale 2 can be used instead to give an approximate focus.

During optical block tilting and shifting, decrease the aperture as far as possible, because unequal amounts of the light falls on the edges and center of the field. It is recommended to use the aperture values from 16 to 22.

When focusing the lens after it has been shifted, it is possible that the microprism and the split-image rangefinder of the viewfinder of the camera may darken. In that case, check the image sharpness on the matte spot of the focusing screen. Orientation based on a distance scale after the lens has been shifted shall not give precise result.

#### 3.3. Aperture operation

Manual aperture operation is provided for in the lens. Select the value by rotation of the ring 5, first pulling it aside along the optical axis towards the camera. In the released condition rotate the ring 5 from set up value to the value 2,8. Before exposure do not forget to rotate the ring 5 until the selected value of the aperture appears.

#### 3.4. Lens shifting

While rotating handle 10, the lens is moving in parallel to the image surface. The lens can be rotated by 360° with settled interval every 30° (the lens can operate even in the positions between these intervals). Due to the fact that the camera's image is rectangular, the limit degree of lens shift will be changing at every rotation. The maximal shift is possible at the settled position of the lens along the image's short side. Control this shift on the scale 11.

#### 3.5. Lens tilting

While rotating tilting handle 7, the lens is tilting. Tilting depends from the direction of rotation of tilting handle 7. The lens can be rotated by 360° with settled interval every 30° (the lens can operate even in the positions between these intervals). Due to the fact that the camera's image is rectangular, the limit degree of lens tilt will be changing at every rotation. The maximal tilt is possible at the tilt angle with the zero position of the shift.

Tilting during photographing, obey the Scheimpflug principal, which states that if a lens is tilted such that the lens plane intersects the film plane, the plane of sharp focus must also pass through that same line of intersection like it shown on the scheme below.

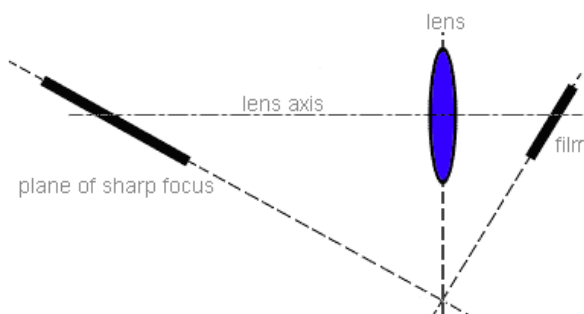

### 3.6. Lens rotating

The lens can be rotated by  $360^\circ$  with settled interval every  $30^\circ$  (the lens can operate even in the positions between these intervals). For  $360^\circ$  lens rotating just rotate the ring 9 clockwise or counter-clockwise. When lens installed on the camera body, you can rotate them also holding lens body or TS plate 6.

### 3.7. Distortion correction

When photographing high buildings from ground level, the distances from the lens from the top and bottom of the subject are radically different. As a result of this, the distortion in this case appears as a convergence of the parallel lines upwards (Figure 4), and vice versa: when photographing from above downwards, the parallel sides of the building will be converging downwards.

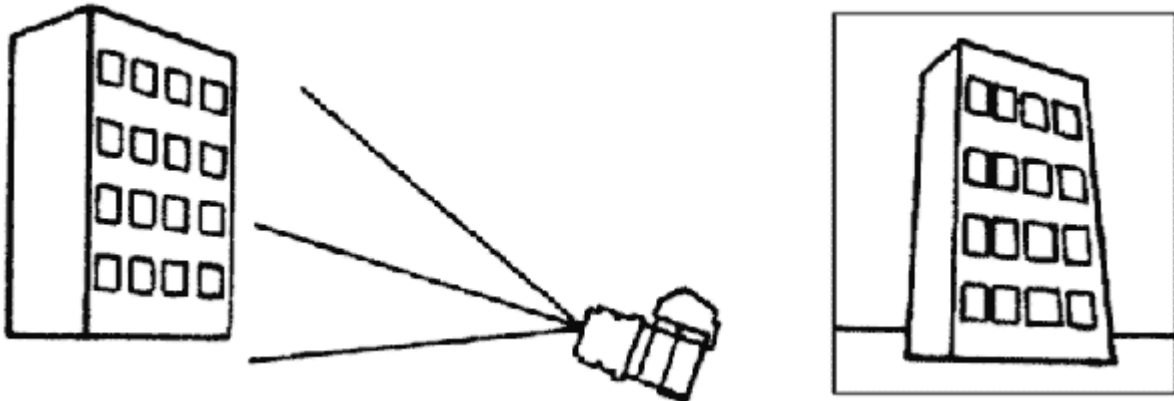

Figure 4

In order to correct such distortion do not incline the camera either upwards or downwards, but maintain the film plane in parallel to the object being photographed (for example, building), thus that film plane of the camera is situated at right angles to the ground. Then, in order to achieve the intended composition the optical block of the lens shall be shifted vertically upwards, due to this the distortion is eliminated. See Figure 5.

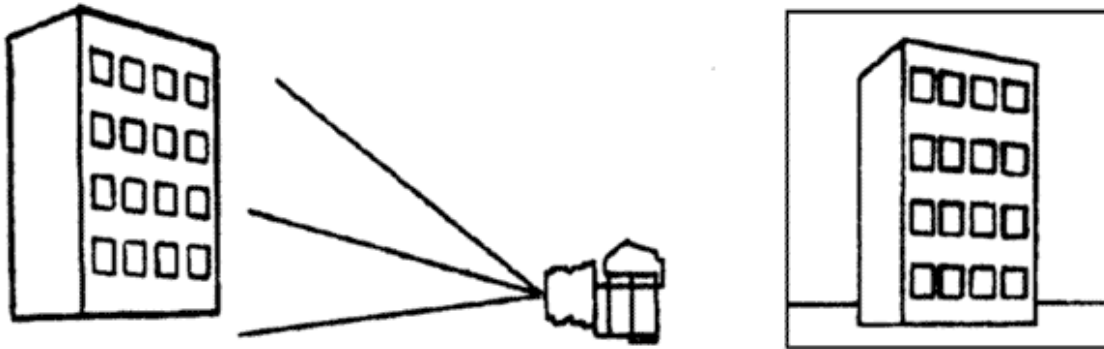

Figure 5

Sometimes instead of image correction, with the intention of creating special effects, the occasion arises to create even more exaggerated distortions. In this case, you would incline the camera upwards and shift the lens in the opposite direction.

### 3.8. Reflection elimination

When photographing objects with reflective surfaces, the reflection of the photographer along with camera can appear on the image. (Figure 6A). Carrying over the camera angle to one side and shifting the lens to the opposite side, while retaining the parallelism of the object and film planes allows you to eliminate the reflection and still preserve the rectangular composition of the image (Figure 6B).

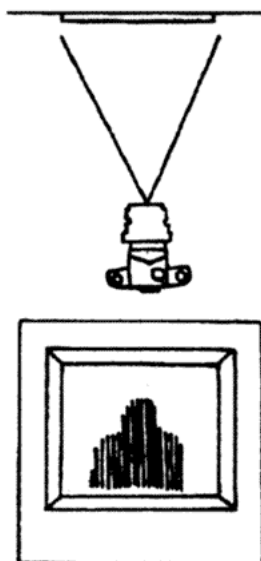

Figure 6A

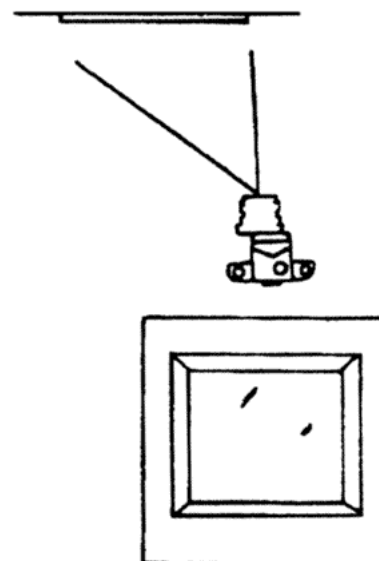

Figure 6B

### 3.9. Panoramas

While using a lens with shift capability you can produce panoramic photographs. For that, make two exposures from one camera angle: first one – with maximum shift of the lens to the right, and a second one – with maximum shift to the left. Combining both images will provide you with a single panoramic photograph (Figure 7), which corresponds to a negative with an image format of 6x9 cm and normal perspective.

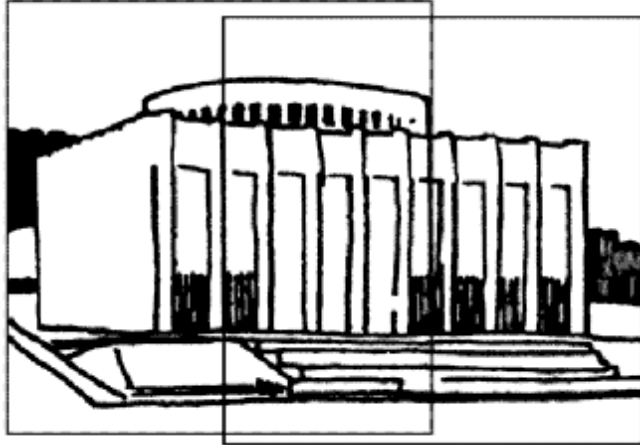

Figure 7

### 3.10. Obstruction elimination

Obstructions like trees or telegraph poles located relatively closely to the camera and appearing at the image edge can be eliminated by means of lens shifting and rotating the camera.

For instance, the obstruction (pole) is located at the image edge on the right. See Figure 8A. To eliminate it, shift the lens to the right, and rotate the camera to the left until full disappearance of the pole. (Figure 8B).

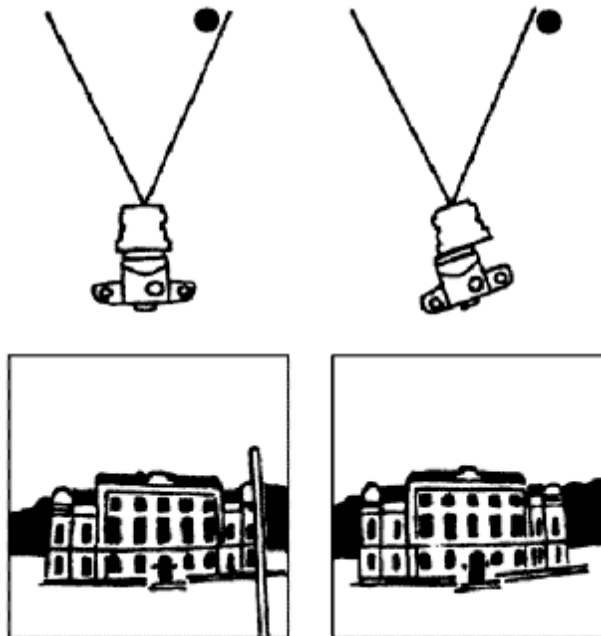

Figure 8A

Figure 8B

## 4. STORAGE AND MAINTENANCE RULES

The camera lens is a complicated optical device and it requires careful operation and maintenance. Protect it against impacts, sudden fluctuations in temperature and also against dust and moisture.

Upon entrance into a warm room from outside frost do not open the lens immediately. Let it warm up to prevent condensation on the optical surfaces.

Remove dust and moisture from the lens with a soft brush, cloth, or a product specific to this purpose.

**Note:** During inspection it can be found out that some lenses may have small bubbles in the glass, insignificant scratches and fluffs which do not in any way affect image quality and have been accepted by the ARAX standard.

Version 3 (07-26-2011)



**ARAX Inc.**

Kiev, Ukraine, 01042

[www.araxfoto.com](http://www.araxfoto.com)

[info@araxfoto.com](mailto:info@araxfoto.com)